

Air Array

Key features:

- Three-way bi-amped sculpted loudspeaker array
- Line source radiation pattern
- Low resonance fibreglass composite construction
- 14 discrete proprietary drivers
- Integrated flying and mounting system
- Ground stack on subwoofers
- Optional floor stand or flying bracket

Applications:

- High impact nightclub
- Indoor and outdoor dance events
- Live music venues

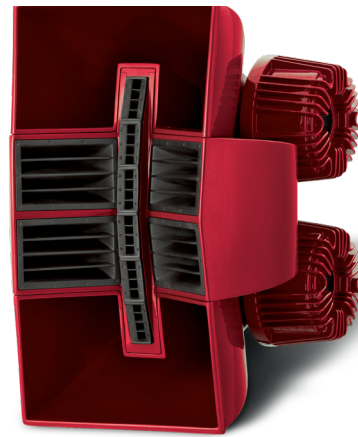

As the mid-high element of the Incubus system, the Air Array's radical looks are purposefully designed to form a coherent radiation pattern, where the sound pressure level in the near field is matched with that at greater distances, while HF absorption is corrected with linear frequency shading. The line source configuration makes the Air Array the only mid-high enclosure that can provide constant SPL at all distances, with all frequencies arriving at the same time wherever you are within its coverage. The heatsink cooling system reinforces reliability and reduces power compression levels, resulting in exceptional output with the highest definition.

Specifications

Frequency Response	90 Hz - 26 kHz ± 3 dB
Efficiency ¹	LF: 111 dB 1W/1m, MF: 114 dB 1W/1m, HF: 116 dB 1W/1m
Crossover Points	Preset via dedicated processor
Nominal Impedance	LF: 2 x 4 Ω , MF: 2 x 4 Ω , HF: 2 x 5.33 Ω
Power Handling ²	LF: 3600 W AES, MF: 800 W AES, HF: 320 W AES
Maximum Output ³	146 dB cont, 152 dB peak
Driver Configuration	4 x 12" LF, 4 x 3" MF compression driver, 6 x 1" HF compression driver
Dispersion	90°H x 45°V
Connectors	2 x 8-pole speakON™ NL8
Weight	144.8 kg (319.2 lbs) including stand
Enclosure	Fibreglass composite
Rigging	Stack mounted or proprietary suspension system
Finish	Smooth cellulose

¹ Measured in half space ² AES2 - 1984 compliant ³ Calculated

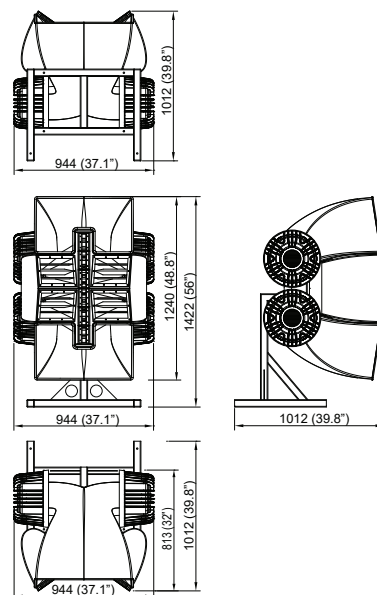

Air Array

Architectural specifications

The loudspeaker shall be an active three-way system with independent dedicated amplification consisting of four high power 12" (304.8 mm) horn loaded low frequency (LF) transducers, a mid frequency section consisting four 3" (76.2 mm) mid frequency (MF) compression drivers with attached waveguides and six 1" (25.4 mm) high frequency (HF) compression driver mounted on a waveguide to allow constant directivity.

Two hyperbolic horns fed from a split manifold and driven by the four LF transducers shall provide the low frequency section. Each LF transducer shall be enclosed in an independent moulded fibreglass enclosure featuring a heatsink cooling system to reduce power compression levels. Mid frequency transducers are in a sealed enclosure mounted in a V baffle configuration for a more coherent radiation pattern over frequency range. HF transducers shall be arranged in a line source configuration positioned on a physical arc, providing a virtual common feed point, resulting in an improved directivity pattern control and higher SPL over the high frequency range. Line source behavioural conditions are met by all sections hence allowing frequency and power shading within a single enclosure.

The LF transducers shall be constructed on a cast aluminium frame, with a treated paper cone, 101.6 mm (4") voice coil, wound with copper wires on a high quality voice coil former and neodymium magnets, for high power handling and long term-reliability. Each 3" MF transducer shall have a 6" diaphragm reproducing frequencies down to 500 Hz, and shall be mounted on a high standard waveguide

with path length compensation for a better directivity pattern control over the frequency spectrum. The HF transducers shall project sound through a high precision planar waveguide to achieve pattern control and low distortion.

Performance specifications for a typical production unit shall be as follows: the usable on-axis bandwidth shall be 90 Hz to 26 kHz (± 3 dB), with an average 45° directivity pattern on the vertical axis and 90° on the horizontal one (-6 dB down from on-axis level) from 1 kHz to 12 kHz; maximum SPL of 152 dB peak measured at 1 m using IEC268-5 pink noise. Power handling shall be 3600 W AES for the LF section at a rated impedance of $2 \times 4 \Omega$, 800 W AES for the MF section at a rated impedance of $2 \times 4 \Omega$ and 320 W AES for the HF section at a rated impedance $2 \times 5.3 \Omega$. The system shall be powered by its own dedicated power amplification modules with DSP management, from which crossover points will also be set. The wiring connection shall be via two Neutrik speakON™ NL8. The left NL8 shall be used to power the LF section and the right one shall power the MHF section.

The enclosure shall be of a fibreglass composite with a smooth cellulose finish of any RAL colour. The system shall be stack mounted with a dedicated stand or can also be flown with a load tested suspension system. The external dimensions of the enclosure shall be (W) 944 mm x (H) 1240 mm x (D) 813 mm (37.2" x 48.8" x 32"). Weight shall be 144.8 kg (319.2 lbs) including stand.

The loudspeaker shall be the Void Acoustics Air Array.