

# LGMG

## PUSH AROUND VERTICAL MAST LIFTS

- Compact in size, easy access to hard-to-reach area.
- Six-wheel design for more agile movement.
- Four outriggers interlock provide more stability.
- Convenient loading, easy to transport, saving labor cost.

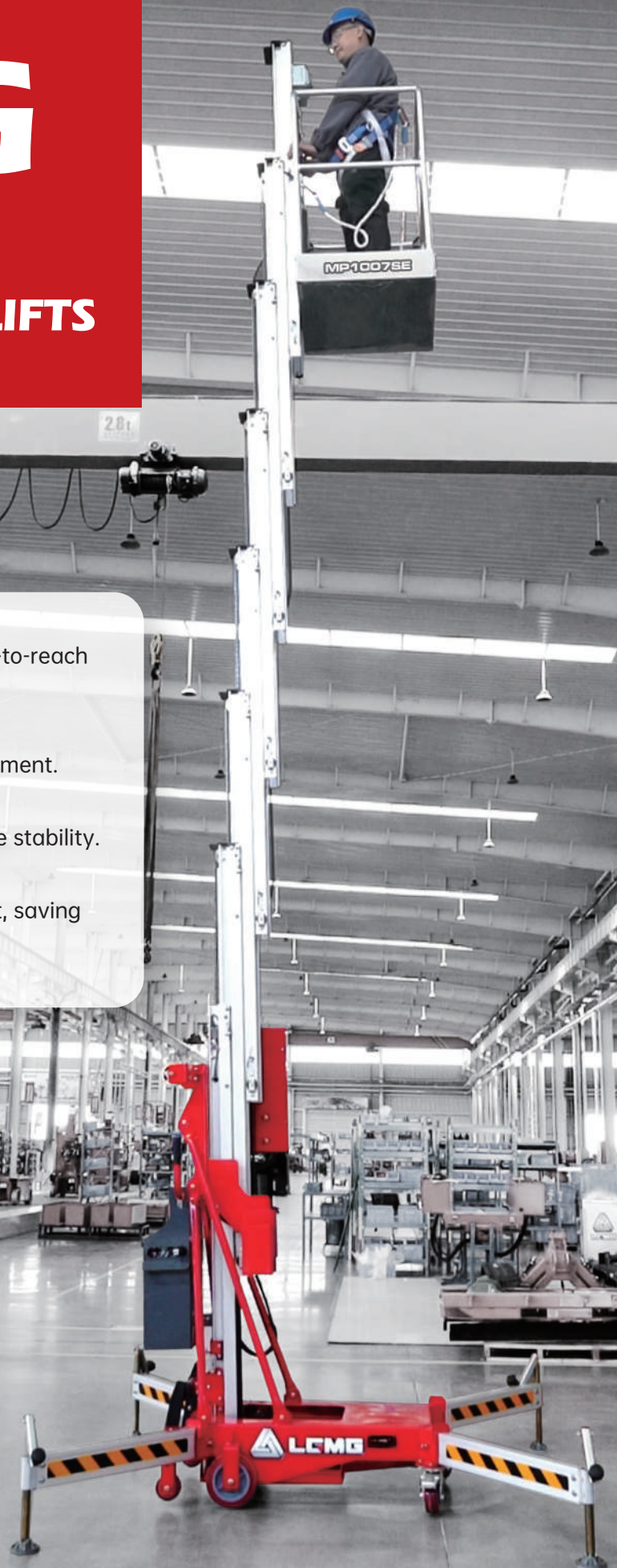

# LGMG VERTICAL MAST LIFTS

## SPECIFICATIONS

MODELS	MP0507SE	MP0607SE	MP0807SE	MP0907SE	MP1007SE	MP1208SE
Working Height Max.	6.7m	8.2m	9.6m	10.9m	12.1m	14m
<b>A</b> Platform Height (Raised)	4.7m	6.2m	7.6m	8.9m	10.1m	12m
Platform Size	0.67x0.66m					
<b>B</b> Overall Length	1.24m	1.24m	1.36m	1.4m	1.42m	1.46m
<b>C</b> Overall Width	0.8m	0.8m	0.78m	0.78m	0.78m	0.8m
<b>D</b> Overall Height	1.99m	1.99m	1.99m	1.99m	1.99m	2.68m
<b>E</b> Wheelbase	0.8m	0.8m	0.8m	0.8m	0.8m	0.8m
Ground Clearance (Stowed/Raised)	52/52mm	52/52mm	52/52mm	52/52mm	52/52mm	52/52mm
<b>PRODUCTIVITY</b>						
Max. Platform Occupants	1					
Platform Capacity	150kg	150kg	150kg	150kg	136kg	120kg
Raise/Lower Speed	22s / 23s	26s / 38s	27s / 35s	28s / 32s	36s / 30s	40s / 60s
Max. Wind Speed	0m/s					
Rear Wheels	200x50mm					
Front Caster Wheels	125x50mm					
<b>POWER</b>						
Power Source	12V 100Ah					
Charger	12V / 15A					
<b>WEIGHT</b>						
Machine Weight	379kg	396kg	435kg	464kg	490kg	571kg

## STANDARD FEATURES

Outrigger Interlock
Deadman Switch
Leveling Bubble
Forklift Pocket
Emergency Stop Button
Easily Loading To Pickup Truck
Emergency Lowering System
Cylinder Holding Valve

## OPTIONAL

Ac Power On Platform
----------------------

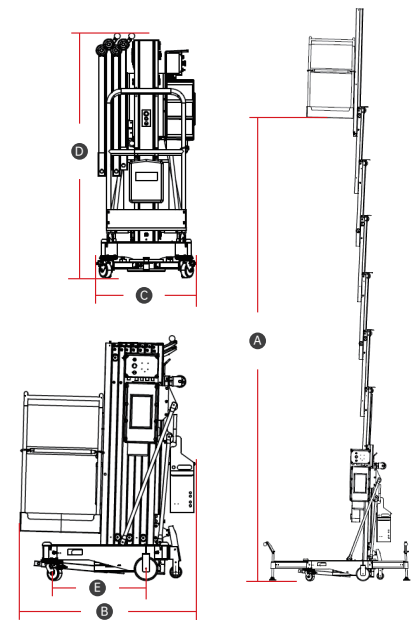

Please contact LGMG or a local dealer for more details.

LGMG reserves the right to change technical data without prior notice. All photos and pictures in this brochure are for promotional purposes only.

## LINGONG HEAVY MACHINERY CO., LTD.

Address: No. 2676, Kejia Road, Jinan, Shandong, China  
 Email: sales@lgmg.com.cn Tel: +86 531 6787 9283

www.lgmglifts.com



RELIABILITY IN ACTION